

# Rope Handbag

by Ellen Lockett Baker of *The Long Thread*

## Supplies:

1/2 yard cotton or linen outer fabric  
1/2 yard canvas lining  
matching thread  
2 yards cotton rope or trim  
masking tape (or metal clamps)

Seam allowance: 1/2"

1. Cut fabric according to the dimensions in fig. A. Cut the rope into two 30" segments.

2. Pin lining fabric together, right sides facing, and stitch along the outside, stopping 6" from the top. Leave a 5" opening in the bottom (for turning the bag right sides out in a later step). See fig. B. Repeat with the outer fabric pieces, but *do not* leave an opening in the bottom of the outer bag. Press all seams open.

3. Turn the outer bag right sides out and insert it into the lining so that the right sides are facing one another. Pin and sew the pieces together along the top edge as shown in fig. C.

4. Pull the bag right sides out through the opening in the lining. Press and topstitch along the opening. Push the lining into the bag and press along the top.

5. With one 30" each piece of rope, hold the ends together to form a loop. Baste the ends together with a hand sewing needle and thread. Wrap the masking tape around the ends to secure them. Alternately, you could use metal clamps to secure the ends. Repeat with the other piece of rope.

6. Fold over the top edge of one side of the bag by about 2" onto a rope handle and use a couple of pins to secure it. Begin hand sewing the lining to itself using a ladder stitch. Continue pinning and sewing until you have reached the end. Repeat with the other rope handle on the opposite side of the bag. If you used tape to secure the rope, you will want to stitch the taped portion to the bag to secure it in place where it is not showing.



Fig. A

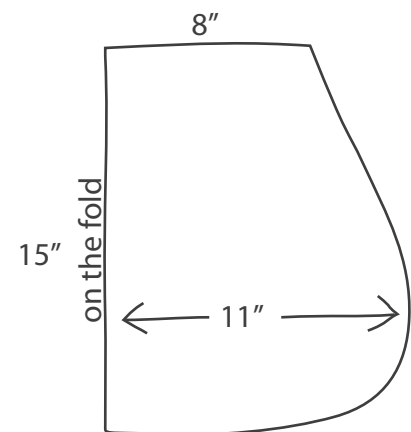

Fig. B

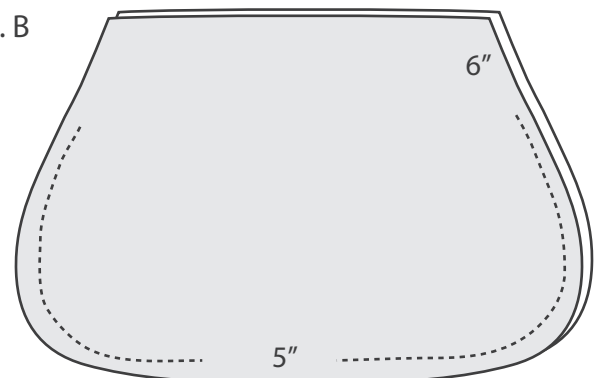

Fig. C

